

Panther®

Synchronous Drive Belt



1 Ultra-Cord® Tensile Member
High strength
Low tension decay
Dimensional stability

2 Nylon Tooth Facing
Graphite-loaded
Self-lubricating
Wear resistant

3 RPP® Profile
Efficient transfer of power
Jump and shear resistant
Quiet

4 Rubber Backing
Precision-ground
Smooth operation with backside idler

5 Advanced Polymer Compound
Excellent performance
Long belt life

Recommended Sprockets:
High Torque Synchronous (HTS) Sprockets – MPB, OD, Taper Bushed (8mm, 14mm, 20mm)

Optimized tensile member

Advanced polymer compound

Maintenance-free

Energy efficient

Applications:

Conveyors

Blowers

Packaging equipment

Machine tools

Industrial machinery

& More

Synchronous Belts

V-Belts

Specialty Belts

Tools

General Information

Panther®

Synchronous Drive Belt

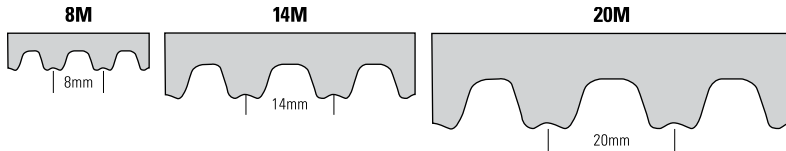

Panther® is designed to improve performance and drive life while reducing maintenance and downtime.

The energy efficient Panther® belt

offers higher torque capacity than Timken Synchro-Cog® HT belts..

- **Strong** – Panther belts shrugs off shock loads. Designed with Ultra-Cord, to deliver strength and dimensional stability.
- **Resilient** – Uniquely engineered teeth are made of an advanced polymer compound for high performance and long belt life. The tooth facing is graphite loaded, self-lubricating, and wear resistant. The RPP® profile offers superior performance in RPP, HTS and PGGT2® sprockets as well as HPPD, Hawk Pd® and HTD® sprockets.
- **Energy Efficient** – Panther belts perform at 98-99% operating efficiency for reduced energy consumption.
- **Panther Power** – Panther Panther belts are maintenance free while offering higher power ratings than conventional rubber synchronous belts. Available in 8, 14 and 20mm pitches.



Hawk Pd® is a registered trademark of Veyance Technologies, Inc. PGGT2® and HTD® are registered trademarks of Gates Corporation.

Panther® Synchronous Drive Belt

Panther® Part Numbers

Part Number Example: **1400-8MPT-50** = **1400** - **8M** **PT** - **50**
Pitch Length (millimeters) Tooth Pitch Panther Construction (RPP tooth profile) Width (millimeters)

Part Number	Number Of Teeth	Pitch Length		Weight (lbs)
		(mm)	(in)	
8M Pitch – High Torque Synchronous (HTS) Sprockets: MPB, QD, Taper Bushed (8mm)				
480-8MPT-12	60	480	18.9	0.07
480-8MPT-20	60	480	18.9	0.12
480-8MPT-22	60	480	18.9	0.13
480-8MPT-30	60	480	18.9	0.17
480-8MPT-35	60	480	18.9	0.20
480-8MPT-50	60	480	18.9	0.29
480-8MPT-60	60	480	18.9	0.35
480-8MPT-85	60	480	18.9	0.49
560-8MPT-12	70	560	22.0	0.08
560-8MPT-20	70	560	22.0	0.14
560-8MPT-22	70	560	22.0	0.15
560-8MPT-30	70	560	22.0	0.20
560-8MPT-35	70	560	22.0	0.24
560-8MPT-50	70	560	22.0	0.34
560-8MPT-60	70	560	22.0	0.41
560-8MPT-85	70	560	22.0	0.57
600-8MPT-12	75	600	23.6	0.09
600-8MPT-20	75	600	23.6	0.14
600-8MPT-22	75	600	23.6	0.16
600-8MPT-30	75	600	23.6	0.22
600-8MPT-35	75	600	23.6	0.25
600-8MPT-50	75	600	23.6	0.36
600-8MPT-60	75	600	23.6	0.43
600-8MPT-85	75	600	23.6	0.61
640-8MPT-12	80	640	25.2	0.09
640-8MPT-20	80	640	25.2	0.15
640-8MPT-22	80	640	25.2	0.17
640-8MPT-30	80	640	25.2	0.23
640-8MPT-35	80	640	25.2	0.27
640-8MPT-50	80	640	25.2	0.39
640-8MPT-60	80	640	25.2	0.46
640-8MPT-85	80	640	25.2	0.66
720-8MPT-12	90	720	28.3	0.10

Part Number	Number Of Teeth	Pitch Length		Weight (lbs)
		(mm)	(in)	
8M Pitch – High Torque Synchronous (HTS) Sprockets: MPB, QD, Taper Bushed (8mm)				
720-8MPT-20	90	720	28.3	0.17
720-8MPT-22	90	720	28.3	0.19
720-8MPT-30	90	720	28.3	0.26
720-8MPT-35	90	720	28.3	0.30
720-8MPT-50	90	720	28.3	0.43
720-8MPT-60	90	720	28.3	0.52
720-8MPT-85	90	720	28.3	0.74
800-8MPT-12	100	800	31.5	0.12
800-8MPT-20	100	800	31.5	0.19
800-8MPT-22	100	800	31.5	0.21
800-8MPT-30	100	800	31.5	0.29
800-8MPT-35	100	800	31.5	0.34
800-8MPT-50	100	800	31.5	0.48
800-8MPT-60	100	800	31.5	0.58
800-8MPT-85	100	800	31.5	0.82
880-8MPT-12	110	880	34.6	0.13
880-8MPT-20	110	880	34.6	0.21
880-8MPT-22	110	880	34.6	0.23
880-8MPT-30	110	880	34.6	0.32
880-8MPT-35	110	880	34.6	0.37
880-8MPT-50	110	880	34.6	0.53
880-8MPT-60	110	880	34.6	0.64
880-8MPT-85	110	880	34.6	0.90
896-8MPT-12	112	896	35.3	0.13
896-8MPT-20	112	896	35.3	0.22
896-8MPT-22	112	896	35.3	0.24
896-8MPT-30	112	896	35.3	0.32
896-8MPT-35	112	896	35.3	0.38
896-8MPT-50	112	896	35.3	0.54
896-8MPT-60	112	896	35.3	0.65
896-8MPT-85	112	896	35.3	0.92
920-8MPT-12	115	920	36.2	0.13
920-8MPT-20	115	920	36.2	0.22

Panther®

Synchronous Drive Belt

Panther® Part Numbers

Part Number	Number Of Teeth	Pitch Length		Weight (lbs)
		(mm)	(in)	
8M Pitch – High Torque Synchronous (HTS) Sprockets: MPB, QD, Taper Bushed (8mm)				
920-8MPT-22	115	920	36.2	0.24
920-8MPT-30	115	920	36.2	0.33
920-8MPT-35	115	920	36.2	0.39
920-8MPT-50	115	920	36.2	0.55
920-8MPT-60	115	920	36.2	0.67
920-8MPT-85	115	920	36.2	0.94
960-8MPT-12	120	960	37.8	0.14
960-8MPT-20	120	960	37.8	0.23
960-8MPT-22	120	960	37.8	0.25
960-8MPT-30	120	960	37.8	0.35
960-8MPT-35	120	960	37.8	0.41
960-8MPT-50	120	960	37.8	0.58
960-8MPT-60	120	960	37.8	0.69
960-8MPT-85	120	960	37.8	0.98
1000-8MPT-12	125	1000	39.4	0.14
1000-8MPT-20	125	1000	39.4	0.24
1000-8MPT-22	125	1000	39.4	0.27
1000-8MPT-30	125	1000	39.4	0.36
1000-8MPT-35	125	1000	39.4	0.42
1000-8MPT-50	125	1000	39.4	0.60
1000-8MPT-60	125	1000	39.4	0.72
1000-8MPT-85	125	1000	39.4	1.02
1040-8MPT-12	130	1040	40.9	0.15
1040-8MPT-20	130	1040	40.9	0.25
1040-8MPT-22	130	1040	40.9	0.28
1040-8MPT-30	130	1040	40.9	0.38
1040-8MPT-35	130	1040	40.9	0.44
1040-8MPT-50	130	1040	40.9	0.63
1040-8MPT-60	130	1040	40.9	0.75
1040-8MPT-85	130	1040	40.9	1.07
1120-8MPT-12	140	1120	44.1	0.16
1120-8MPT-20	140	1120	44.1	0.27
1120-8MPT-22	140	1120	44.1	0.30

Part Number	Number Of Teeth	Pitch Length		Weight (lbs)
		(mm)	(in)	
8M Pitch – High Torque Synchronous (HTS) Sprockets: MPB, QD, Taper Bushed (8mm)				
1120-8MPT-30	140	1120	44.1	0.41
1120-8MPT-35	140	1120	44.1	0.47
1120-8MPT-50	140	1120	44.1	0.68
1120-8MPT-60	140	1120	44.1	0.81
1120-8MPT-85	140	1120	44.1	1.15
1152-8MPT-12	144	1152	45.4	0.17
1152-8MPT-20	144	1152	45.4	0.28
1152-8MPT-22	144	1152	45.4	0.31
1152-8MPT-30	144	1152	45.4	0.42
1152-8MPT-35	144	1152	45.4	0.49
1152-8MPT-50	144	1152	45.4	0.69
1152-8MPT-60	144	1152	45.4	0.83
1152-8MPT-85	144	1152	45.4	1.18
1200-8MPT-12	150	1200	47.2	0.17
1200-8MPT-20	150	1200	47.2	0.29
1200-8MPT-22	150	1200	47.2	0.32
1200-8MPT-30	150	1200	47.2	0.43
1200-8MPT-35	150	1200	47.2	0.51
1200-8MPT-50	150	1200	47.2	0.72
1200-8MPT-60	150	1200	47.2	0.87
1200-8MPT-85	150	1200	47.2	1.23
1224-8MPT-12	153	1224	48.2	0.18
1224-8MPT-20	153	1224	48.2	0.30
1224-8MPT-22	153	1224	48.2	0.32
1224-8MPT-30	153	1224	48.2	0.44
1224-8MPT-35	153	1224	48.2	0.52
1224-8MPT-50	153	1224	48.2	0.74
1224-8MPT-60	153	1224	48.2	0.89
1224-8MPT-85	153	1224	48.2	1.25
1248-8MPT-12	156	1248	49.1	0.18
1248-8MPT-20	156	1248	49.1	0.30
1248-8MPT-22	156	1248	49.1	0.33
1248-8MPT-30	156	1248	49.1	0.45

Panther® Synchronous Drive Belt

Part Number Example: **1400-8MPT-50** = **1400** - **8M** **PT** - **50**
Pitch Length (millimeters) Tooth Pitch Panther Construction (RPP tooth profile) Width (millimeters)

Part Number	Number Of Teeth	Pitch Length		Weight (lbs)
		(mm)	(in)	
8M Pitch – High Torque Synchronous (HTS) Sprockets: MPB, QD, Taper Bushed (8mm)				
1248-8MPT-35	156	1248	49.1	0.53
1248-8MPT-50	156	1248	49.1	0.75
1248-8MPT-60	156	1248	49.1	0.90
1248-8MPT-85	156	1248	49.1	1.28
1280-8MPT-12	160	1280	50.4	0.19
1280-8MPT-20	160	1280	50.4	0.31
1280-8MPT-22	160	1280	50.4	0.34
1280-8MPT-30	160	1280	50.4	0.46
1280-8MPT-35	160	1280	50.4	0.54
1280-8MPT-50	160	1280	50.4	0.77
1280-8MPT-60	160	1280	50.4	0.93
1280-8MPT-85	160	1280	50.4	1.31
1360-8MPT-12	170	1360	53.5	0.20
1360-8MPT-20	170	1360	53.5	0.33
1360-8MPT-22	170	1360	53.5	0.36
1360-8MPT-30	170	1360	53.5	0.49
1360-8MPT-35	170	1360	53.5	0.57
1360-8MPT-50	170	1360	53.5	0.82
1360-8MPT-60	170	1360	53.5	0.98
1360-8MPT-85	170	1360	53.5	1.39
1400-8MPT-12	175	1400	55.1	0.20
1400-8MPT-20	175	1400	55.1	0.34
1400-8MPT-22	175	1400	55.1	0.37
1400-8MPT-30	175	1400	55.1	0.51
1400-8MPT-35	175	1400	55.1	0.59
1400-8MPT-50	175	1400	55.1	0.84
1400-8MPT-60	175	1400	55.1	1.01
1400-8MPT-85	175	1400	55.1	1.43
1440-8MPT-12	180	1440	56.7	0.21
1440-8MPT-20	180	1440	56.7	0.35
1440-8MPT-22	180	1440	56.7	0.38
1440-8MPT-30	180	1440	56.7	0.52
1440-8MPT-35	180	1440	56.7	0.61

Part Number	Number Of Teeth	Pitch Length		Weight (lbs)
		(mm)	(in)	
8M Pitch – High Torque Synchronous (HTS) Sprockets: MPB, QD, Taper Bushed (8mm)				
1440-8MPT-50	180	1440	56.7	0.87
1440-8MPT-60	180	1440	56.7	1.04
1440-8MPT-85	180	1440	56.7	1.48
1600-8MPT-12	200	1600	63.0	0.23
1600-8MPT-20	200	1600	63.0	0.39
1600-8MPT-22	200	1600	63.0	0.42
1600-8MPT-30	200	1600	63.0	0.58
1600-8MPT-35	200	1600	63.0	0.68
1600-8MPT-50	200	1600	63.0	0.96
1600-8MPT-60	200	1600	63.0	1.16
1600-8MPT-85	200	1600	63.0	1.64
1760-8MPT-12	220	1760	69.3	0.25
1760-8MPT-20	220	1760	69.3	0.42
1760-8MPT-22	220	1760	69.3	0.47
1760-8MPT-30	220	1760	69.3	0.64
1760-8MPT-35	220	1760	69.3	0.74
1760-8MPT-50	220	1760	69.3	1.06
1760-8MPT-60	220	1760	69.3	1.27
1760-8MPT-85	220	1760	69.3	1.80
1800-8MPT-12	225	1800	70.9	0.26
1800-8MPT-20	225	1800	70.9	0.43
1800-8MPT-22	225	1800	70.9	0.48
1800-8MPT-30	225	1800	70.9	0.65
1800-8MPT-35	225	1800	70.9	0.76
1800-8MPT-50	225	1800	70.9	1.09
1800-8MPT-60	225	1800	70.9	1.30
1800-8MPT-85	225	1800	70.9	1.84
1904-8MPT-12	238	1904	75.0	0.28
1904-8MPT-20	238	1904	75.0	0.46
1904-8MPT-22	238	1904	75.0	0.51
1904-8MPT-30	238	1904	75.0	0.69
1904-8MPT-35	238	1904	75.0	0.80
1904-8MPT-50	238	1904	75.0	1.15

Panther®

Synchronous Drive Belt

Panther® Part Numbers

Part Number	Number Of Teeth	Pitch Length		Weight (lbs)
		(mm)	(in)	
8M Pitch – High Torque Synchronous (HTS) Sprockets: MPB, QD, Taper Bushed (8mm)				
1904-8MPT-60	238	1904	75.0	1.38
1904-8MPT-85	238	1904	75.0	1.95
2000-8MPT-12	250	2000	78.7	0.29
2000-8MPT-20	250	2000	78.7	0.48
2000-8MPT-22	250	2000	78.7	0.53
2000-8MPT-30	250	2000	78.7	0.72
2000-8MPT-35	250	2000	78.7	0.84
2000-8MPT-50	250	2000	78.7	1.21
2000-8MPT-60	250	2000	78.7	1.45
2000-8MPT-85	250	2000	78.7	2.05
2104-8MPT-12	263	2104	82.8	0.30
2104-8MPT-20	263	2104	82.8	0.51
2104-8MPT-22	263	2104	82.8	0.56
2104-8MPT-30	263	2104	82.8	0.76
2104-8MPT-35	263	2104	82.8	0.89
2104-8MPT-50	263	2104	82.8	1.27
2104-8MPT-60	263	2104	82.8	1.52
2104-8MPT-85	263	2104	82.8	2.16
2200-8MPT-12	275	2200	86.6	0.32
2200-8MPT-20	275	2200	86.6	0.53
2200-8MPT-22	275	2200	86.6	0.58
2200-8MPT-30	275	2200	86.6	0.80
2200-8MPT-35	275	2200	86.6	0.93
2200-8MPT-50	275	2200	86.6	1.33
2200-8MPT-60	275	2200	86.6	1.59
2200-8MPT-85	275	2200	86.6	2.25
2240-8MPT-12	280	2240	88.2	0.32
2240-8MPT-20	280	2240	88.2	0.54
2240-8MPT-22	280	2240	88.2	0.59
2240-8MPT-30	280	2240	88.2	0.81
2240-8MPT-35	280	2240	88.2	0.95
2240-8MPT-50	280	2240	88.2	1.35
2240-8MPT-60	280	2240	88.2	1.62

Part Number	Number Of Teeth	Pitch Length		Weight (lbs)
		(mm)	(in)	
8M Pitch – High Torque Synchronous (HTS) Sprockets: MPB, QD, Taper Bushed (8mm)				
2240-8MPT-85	280	2240	88.2	2.30
2400-8MPT-12	300	2400	94.5	0.35
2400-8MPT-20	300	2400	94.5	0.58
2400-8MPT-22	300	2400	94.5	0.64
2400-8MPT-30	300	2400	94.5	0.87
2400-8MPT-35	300	2400	94.5	1.01
2400-8MPT-50	300	2400	94.5	1.45
2400-8MPT-60	300	2400	94.5	1.74
2400-8MPT-85	300	2400	94.5	2.46
2600-8MPT-12	325	2600	102.4	0.38
2600-8MPT-20	325	2600	102.4	0.63
2600-8MPT-22	325	2600	102.4	0.69
2600-8MPT-30	325	2600	102.4	0.94
2600-8MPT-35	325	2600	102.4	1.10
2600-8MPT-50	325	2600	102.4	1.57
2600-8MPT-60	325	2600	102.4	1.88
2600-8MPT-85	325	2600	102.4	2.66
2800-8MPT-12	350	2800	110.2	0.41
2800-8MPT-20	350	2800	110.2	0.68
2800-8MPT-22	350	2800	110.2	0.74
2800-8MPT-30	350	2800	110.2	1.01
2800-8MPT-35	350	2800	110.2	1.18
2800-8MPT-50	350	2800	110.2	1.69
2800-8MPT-60	350	2800	110.2	2.03
2800-8MPT-85	350	2800	110.2	2.87
3048-8MPT-12	381	3048	120.0	0.44
3048-8MPT-20	381	3048	120.0	0.74
3048-8MPT-22	381	3048	120.0	0.81
3048-8MPT-30	381	3048	120.0	1.10
3048-8MPT-35	381	3048	120.0	1.29
3048-8MPT-50	381	3048	120.0	1.84
3048-8MPT-60	381	3048	120.0	2.21
3048-8MPT-85	381	3048	120.0	3.12

Panther® Synchronous Drive Belt

Part Number Example: **2240-8MPT-85** = **2240** - **8M** **PT** - **85**
Pitch Length (millimeters) Tooth Pitch Panther Construction (RPP tooth profile) Width (millimeters)

Part Number	Number Of Teeth	Pitch Length		Weight (lbs)
		(mm)	(in)	
8M Pitch – High Torque Synchronous (HTS) Sprockets: MPB, QD, Taper Bushed (8mm)				
3280-8MPT-12	410	3280	129.1	0.47
3280-8MPT-20	410	3280	129.1	0.79
3280-8MPT-22	410	3280	129.1	0.87
3280-8MPT-30	410	3280	129.1	1.19
3280-8MPT-35	410	3280	129.1	1.38
3280-8MPT-50	410	3280	129.1	1.98
3280-8MPT-60	410	3280	129.1	2.37
3280-8MPT-85	410	3280	129.1	3.36
3600-8MPT-12	450	3600	141.7	0.52
3600-8MPT-20	450	3600	141.7	0.87
3600-8MPT-22	450	3600	141.7	0.96
3600-8MPT-30	450	3600	141.7	1.30
3600-8MPT-35	450	3600	141.7	1.52
3600-8MPT-50	450	3600	141.7	2.17
3600-8MPT-60	450	3600	141.7	2.60
3600-8MPT-85	450	3600	141.7	3.69
4400-8MPT-12	550	4400	173.2	0.64
4400-8MPT-20	550	4400	173.2	1.06
4400-8MPT-22	550	4400	173.2	1.17
4400-8MPT-30	550	4400	173.2	1.59
4400-8MPT-35	550	4400	173.2	1.86
4400-8MPT-50	550	4400	173.2	2.65
4400-8MPT-60	550	4400	173.2	3.18
4400-8MPT-85	550	4400	173.2	4.51
14M Pitch – High Torque Synchronous (HTS) Sprockets: MPB, QD, Taper Bushed (14mm)				
966-14MPT-20	69	966	38.0	0.39
966-14MPT-40	69	966	38.0	0.77
966-14MPT-42	69	966	38.0	0.81
966-14MPT-55	69	966	38.0	1.06
966-14MPT-65	69	966	38.0	1.26
966-14MPT-85	69	966	38.0	1.65
966-14MPT-90	69	966	38.0	1.74

Part Number	Number Of Teeth	Pitch Length		Weight (lbs)
		(mm)	(in)	
14M Pitch – High Torque Synchronous (HTS) Sprockets: MPB, QD, Taper Bushed (14mm)				
966-14MPT-115	69	966	38.0	2.23
966-14MPT-120	69	966	38.0	2.32
966-14MPT-170	69	966	38.0	3.29
1092-14MPT-20	78	1092	43.0	0.44
1092-14MPT-40	78	1092	43.0	0.88
1092-14MPT-42	78	1092	43.0	0.92
1092-14MPT-55	78	1092	43.0	1.20
1092-14MPT-65	78	1092	43.0	1.42
1092-14MPT-85	78	1092	43.0	1.86
1092-14MPT-90	78	1092	43.0	1.97
1092-14MPT-115	78	1092	43.0	2.52
1092-14MPT-120	78	1092	43.0	2.63
1092-14MPT-170	78	1092	43.0	3.72
1190-14MPT-20	85	1190	46.9	0.48
1190-14MPT-40	85	1190	46.9	0.95
1190-14MPT-42	85	1190	46.9	1.00
1190-14MPT-55	85	1190	46.9	1.31
1190-14MPT-65	85	1190	46.9	1.55
1190-14MPT-85	85	1190	46.9	2.03
1190-14MPT-90	85	1190	46.9	2.15
1190-14MPT-115	85	1190	46.9	2.74
1190-14MPT-120	85	1190	46.9	2.86
1190-14MPT-170	85	1190	46.9	4.05
1400-14MPT-20	100	1400	55.1	0.56
1400-14MPT-40	100	1400	55.1	1.12
1400-14MPT-42	100	1400	55.1	1.18
1400-14MPT-55	100	1400	55.1	1.54
1400-14MPT-65	100	1400	55.1	1.82
1400-14MPT-85	100	1400	55.1	2.38
1400-14MPT-90	100	1400	55.1	2.52
1400-14MPT-115	100	1400	55.1	3.23
1400-14MPT-120	100	1400	55.1	3.37
1400-14MPT-170	100	1400	55.1	4.77

Panther®

Synchronous Drive Belt

Panther®

Part Numbers

Part Number	Number Of Teeth	Pitch Length		Weight (lbs)
		(mm)	(in)	
14M Pitch – High Torque Synchronous (HTS) Sprockets: MPB, OD, Taper Bushed (14mm)				
1610-14MPT-20	115	1610	63.4	0.65
1610-14MPT-40	115	1610	63.4	1.29
1610-14MPT-42	115	1610	63.4	1.35
1610-14MPT-55	115	1610	63.4	1.77
1610-14MPT-65	115	1610	63.4	2.10
1610-14MPT-85	115	1610	63.4	2.74
1610-14MPT-90	115	1610	63.4	2.90
1610-14MPT-115	115	1610	63.4	3.71
1610-14MPT-120	115	1610	63.4	3.87
1610-14MPT-170	115	1610	63.4	5.48
1750-14MPT-20	125	1750	68.9	0.70
1750-14MPT-40	125	1750	68.9	1.40
1750-14MPT-42	125	1750	68.9	1.47
1750-14MPT-55	125	1750	68.9	1.93
1750-14MPT-65	125	1750	68.9	2.28
1750-14MPT-85	125	1750	68.9	2.98
1750-14MPT-90	125	1750	68.9	3.16
1750-14MPT-115	125	1750	68.9	4.03
1750-14MPT-120	125	1750	68.9	4.21
1750-14MPT-170	125	1750	68.9	5.96
1764-14MPT-20	126	1764	69.4	0.71
1764-14MPT-40	126	1764	69.4	1.41
1764-14MPT-42	126	1764	69.4	1.48
1764-14MPT-55	126	1764	69.4	1.94
1764-14MPT-65	126	1764	69.4	2.30
1764-14MPT-85	126	1764	69.4	3.00
1764-14MPT-90	126	1764	69.4	3.18
1764-14MPT-115	126	1764	69.4	4.06
1764-14MPT-120	126	1764	69.4	4.24
1764-14MPT-170	126	1764	69.4	6.01
1778-14MPT-20	127	1778	70.0	0.71
1778-14MPT-40	127	1778	70.0	1.43
1778-14MPT-42	127	1778	70.0	1.50

Part Number	Number Of Teeth	Pitch Length		Weight (lbs)
		(mm)	(in)	
14M Pitch – High Torque Synchronous (HTS) Sprockets: MPB, OD, Taper Bushed (14mm)				
1778-14MPT-55	127	1778	70.0	1.96
1778-14MPT-65	127	1778	70.0	2.32
1778-14MPT-85	127	1778	70.0	3.03
1778-14MPT-90	127	1778	70.0	3.21
1778-14MPT-115	127	1778	70.0	4.10
1778-14MPT-120	127	1778	70.0	4.28
1778-14MPT-170	127	1778	70.0	6.06
1792-14MPT-20	128	1792	70.6	0.72
1792-14MPT-40	128	1792	70.6	1.44
1792-14MPT-42	128	1792	70.6	1.51
1792-14MPT-55	128	1792	70.6	1.97
1792-14MPT-65	128	1792	70.6	2.33
1792-14MPT-85	128	1792	70.6	3.05
1792-14MPT-90	128	1792	70.6	3.23
1792-14MPT-115	128	1792	70.6	4.13
1792-14MPT-120	128	1792	70.6	4.31
1792-14MPT-170	128	1792	70.6	6.10
1820-14MPT-20	130	1820	71.7	0.73
1820-14MPT-40	130	1820	71.7	1.46
1820-14MPT-42	130	1820	71.7	1.53
1820-14MPT-55	130	1820	71.7	2.01
1820-14MPT-65	130	1820	71.7	2.37
1820-14MPT-85	130	1820	71.7	3.10
1820-14MPT-90	130	1820	71.7	3.28
1820-14MPT-115	130	1820	71.7	4.19
1820-14MPT-120	130	1820	71.7	4.38
1820-14MPT-170	130	1820	71.7	6.20
1848-14MPT-20	132	1848	72.8	0.74
1848-14MPT-40	132	1848	72.8	1.48
1848-14MPT-42	132	1848	72.8	1.56
1848-14MPT-55	132	1848	72.8	2.04
1848-14MPT-65	132	1848	72.8	2.41
1848-14MPT-85	132	1848	72.8	3.15

Panther® Synchronous Drive Belt

Part Number Example: **1610-14MPT-20** = **1610** - **14M** **PT** - **20**
Pitch Length (millimeters) Tooth Pitch Panther Construction (RPP tooth profile) Width (millimeters)

Part Number	Number Of Teeth	Pitch Length		Weight (lbs)
		(mm)	(in)	
14M Pitch – High Torque Synchronous (HTS) Sprockets: MPB, QD, Taper Bushed (14mm)				
1848-14MPT-90	132	1848	72.8	3.33
1848-14MPT-115	132	1848	72.8	4.26
1848-14MPT-120	132	1848	72.8	4.44
1848-14MPT-170	132	1848	72.8	6.29
1862-14MPT-20	133	1862	73.3	0.75
1862-14MPT-40	133	1862	73.3	1.49
1862-14MPT-42	133	1862	73.3	1.57
1862-14MPT-55	133	1862	73.3	2.05
1862-14MPT-65	133	1862	73.3	2.43
1862-14MPT-85	133	1862	73.3	3.17
1862-14MPT-90	133	1862	73.3	3.36
1862-14MPT-115	133	1862	73.3	4.29
1862-14MPT-120	133	1862	73.3	4.48
1862-14MPT-170	133	1862	73.3	6.34
1890-14MPT-20	135	1890	74.4	0.76
1890-14MPT-40	135	1890	74.4	1.51
1890-14MPT-42	135	1890	74.4	1.59
1890-14MPT-55	135	1890	74.4	2.08
1890-14MPT-65	135	1890	74.4	2.46
1890-14MPT-85	135	1890	74.4	3.22
1890-14MPT-90	135	1890	74.4	3.41
1890-14MPT-115	135	1890	74.4	4.36
1890-14MPT-120	135	1890	74.4	4.54
1890-14MPT-170	135	1890	74.4	6.44
1904-14MPT-20	136	1904	75.0	0.76
1904-14MPT-40	136	1904	75.0	1.53
1904-14MPT-42	136	1904	75.0	1.60
1904-14MPT-55	136	1904	75.0	2.10
1904-14MPT-65	136	1904	75.0	2.48
1904-14MPT-85	136	1904	75.0	3.24
1904-14MPT-90	136	1904	75.0	3.43
1904-14MPT-115	136	1904	75.0	4.39
1904-14MPT-120	136	1904	75.0	4.58

Part Number	Number Of Teeth	Pitch Length		Weight (lbs)
		(mm)	(in)	
14M Pitch – High Torque Synchronous (HTS) Sprockets: MPB, QD, Taper Bushed (14mm)				
1904-14MPT-170	136	1904	75.0	6.49
1960-14MPT-20	140	1960	77.2	0.79
1960-14MPT-40	140	1960	77.2	1.57
1960-14MPT-42	140	1960	77.2	1.65
1960-14MPT-55	140	1960	77.2	2.16
1960-14MPT-65	140	1960	77.2	2.55
1960-14MPT-85	140	1960	77.2	3.34
1960-14MPT-90	140	1960	77.2	3.53
1960-14MPT-115	140	1960	77.2	4.52
1960-14MPT-120	140	1960	77.2	4.71
1960-14MPT-170	140	1960	77.2	6.68
2100-14MPT-20	150	2100	82.7	0.84
2100-14MPT-40	150	2100	82.7	1.68
2100-14MPT-42	150	2100	82.7	1.77
2100-14MPT-55	150	2100	82.7	2.31
2100-14MPT-65	150	2100	82.7	2.74
2100-14MPT-85	150	2100	82.7	3.58
2100-14MPT-90	150	2100	82.7	3.79
2100-14MPT-115	150	2100	82.7	4.84
2100-14MPT-120	150	2100	82.7	5.05
2100-14MPT-170	150	2100	82.7	7.15
2310-14MPT-20	165	2310	90.9	0.93
2310-14MPT-40	165	2310	90.9	1.85
2310-14MPT-42	165	2310	90.9	1.94
2310-14MPT-55	165	2310	90.9	2.55
2310-14MPT-65	165	2310	90.9	3.01
2310-14MPT-85	165	2310	90.9	3.93
2310-14MPT-90	165	2310	90.9	4.17
2310-14MPT-115	165	2310	90.9	5.32
2310-14MPT-120	165	2310	90.9	5.55
2310-14MPT-170	165	2310	90.9	7.87
2450-14MPT-20	175	2450	96.5	0.98
2450-14MPT-40	175	2450	96.5	1.96

Panther®

Synchronous Drive Belt

Panther®

Part Numbers

Part Number	Number Of Teeth	Pitch Length		Weight (lbs)
		(mm)	(in)	
14M Pitch – High Torque Synchronous (HTS) Sprockets: MPB, OD, Taper Bushed (14mm)				
2450-14MPT-42	175	2450	96.5	2.06
2450-14MPT-55	175	2450	96.5	2.70
2450-14MPT-65	175	2450	96.5	3.19
2450-14MPT-85	175	2450	96.5	4.17
2450-14MPT-90	175	2450	96.5	4.42
2450-14MPT-115	175	2450	96.5	5.65
2450-14MPT-120	175	2450	96.5	5.89
2450-14MPT-170	175	2450	96.5	8.35
2590-14MPT-20	185	2590	102.0	1.04
2590-14MPT-40	185	2590	102.0	2.08
2590-14MPT-42	185	2590	102.0	2.18
2590-14MPT-55	185	2590	102.0	2.85
2590-14MPT-65	185	2590	102.0	3.37
2590-14MPT-85	185	2590	102.0	4.41
2590-14MPT-90	185	2590	102.0	4.67
2590-14MPT-115	185	2590	102.0	5.97
2590-14MPT-120	185	2590	102.0	6.23
2590-14MPT-170	185	2590	102.0	8.82
2800-14MPT-20	200	2800	110.2	1.12
2800-14MPT-40	200	2800	110.2	2.24
2800-14MPT-42	200	2800	110.2	2.36
2800-14MPT-55	200	2800	110.2	3.09
2800-14MPT-65	200	2800	110.2	3.65
2800-14MPT-85	200	2800	110.2	4.77
2800-14MPT-90	200	2800	110.2	5.05
2800-14MPT-115	200	2800	110.2	6.45
2800-14MPT-120	200	2800	110.2	6.73
2800-14MPT-170	200	2800	110.2	9.54
3150-14MPT-20	225	3150	124.0	1.26
3150-14MPT-40	225	3150	124.0	2.52
3150-14MPT-42	225	3150	124.0	2.65
3150-14MPT-55	225	3150	124.0	3.47
3150-14MPT-65	225	3150	124.0	4.10

Part Number	Number Of Teeth	Pitch Length		Weight (lbs)
		(mm)	(in)	
14M Pitch – High Torque Synchronous (HTS) Sprockets: MPB, OD, Taper Bushed (14mm)				
3150-14MPT-85	225	3150	124.0	5.36
3150-14MPT-90	225	3150	124.0	5.68
3150-14MPT-115	225	3150	124.0	7.26
3150-14MPT-120	225	3150	124.0	7.57
3150-14MPT-170	225	3150	124.0	10.73
3360-14MPT-20	240	3360	132.3	1.35
3360-14MPT-40	240	3360	132.3	2.69
3360-14MPT-42	240	3360	132.3	2.83
3360-14MPT-55	240	3360	132.3	3.70
3360-14MPT-65	240	3360	132.3	4.38
3360-14MPT-85	240	3360	132.3	5.72
3360-14MPT-90	240	3360	132.3	6.06
3360-14MPT-115	240	3360	132.3	7.74
3360-14MPT-120	240	3360	132.3	8.08
3360-14MPT-170	240	3360	132.3	11.45
3500-14MPT-20	250	3500	137.8	1.40
3500-14MPT-40	250	3500	137.8	2.81
3500-14MPT-42	250	3500	137.8	2.95
3500-14MPT-55	250	3500	137.8	3.86
3500-14MPT-65	250	3500	137.8	4.56
3500-14MPT-85	250	3500	137.8	5.96
3500-14MPT-90	250	3500	137.8	6.31
3500-14MPT-115	250	3500	137.8	8.07
3500-14MPT-120	250	3500	137.8	8.42
3500-14MPT-170	250	3500	137.8	11.92
3850-14MPT-20	275	3850	151.6	1.54
3850-14MPT-40	275	3850	151.6	3.09
3850-14MPT-42	275	3850	151.6	3.24
3850-14MPT-55	275	3850	151.6	4.24
3850-14MPT-65	275	3850	151.6	5.01
3850-14MPT-85	275	3850	151.6	6.56
3850-14MPT-90	275	3850	151.6	6.94
3850-14MPT-115	275	3850	151.6	8.87

Panther® Synchronous Drive Belt

Part Number Example: **2450-14MPT-42** = **2450** - **14M** **PT** - **42**
Pitch Length (millimeters) Tooth Pitch Panther Construction (RPP tooth profile) Width (millimeters)

Part Number	Number Of Teeth	Pitch Length		Weight (lbs)
		(mm)	(in)	
14M Pitch – High Torque Synchronous (HTS) Sprockets: MPB, QD, Taper Bushed (14mm)				
3850-14MPT-120	275	3850	151.6	9.26
3850-14MPT-170	275	3850	151.6	13.11
4326-14MPT-20	309	4326	170.3	1.73
4326-14MPT-40	309	4326	170.3	3.47
4326-14MPT-42	309	4326	170.3	3.64
4326-14MPT-55	309	4326	170.3	4.77
4326-14MPT-65	309	4326	170.3	5.63
4326-14MPT-85	309	4326	170.3	7.37
4326-14MPT-90	309	4326	170.3	7.80
4326-14MPT-115	309	4326	170.3	9.97
4326-14MPT-120	309	4326	170.3	10.40
4326-14MPT-170	309	4326	170.3	14.74
4578-14MPT-20	327	4578	180.2	1.83
4578-14MPT-40	327	4578	180.2	3.67
4578-14MPT-42	327	4578	180.2	3.85
4578-14MPT-55	327	4578	180.2	5.05
4578-14MPT-65	327	4578	180.2	5.96
4578-14MPT-85	327	4578	180.2	7.80
4578-14MPT-90	327	4578	180.2	8.26
4578-14MPT-115	327	4578	180.2	10.55
4578-14MPT-120	327	4578	180.2	11.01
4578-14MPT-170	327	4578	180.2	15.59
4956-14MPT-20	354	4956	195.1	1.99
4956-14MPT-40	354	4956	195.1	3.97
4956-14MPT-42	354	4956	195.1	4.17
4956-14MPT-55	354	4956	195.1	5.46
4956-14MPT-65	354	4956	195.1	6.45
4956-14MPT-85	354	4956	195.1	8.44
4956-14MPT-90	354	4956	195.1	8.94
4956-14MPT-115	354	4956	195.1	11.42
4956-14MPT-120	354	4956	195.1	11.92
4956-14MPT-170	354	4956	195.1	16.88

Part Number	Number Of Teeth	Pitch Length		Weight (lbs)
		(mm)	(in)	
20M Pitch – High Torque Synchronous (HTS) Sprockets: MPB, QD, Taper Bushed (20mm)				
2000-20MPT-115	100	2000	78.7	7.46
2000-20MPT-170	100	2000	78.7	11.03
2000-20MPT-230	100	2000	78.7	14.92
2000-20MPT-290	100	2000	78.7	18.81
2000-20MPT-340	100	2000	78.7	22.06
2500-20MPT-115	125	2500	98.4	9.33
2500-20MPT-170	125	2500	98.4	13.79
2500-20MPT-230	125	2500	98.4	18.65
2500-20MPT-290	125	2500	98.4	23.52
2500-20MPT-340	125	2500	98.4	27.57
3400-20MPT-115	170	3400	133.9	12.68
3400-20MPT-170	170	3400	133.9	18.75
3400-20MPT-230	170	3400	133.9	25.37
3400-20MPT-290	170	3400	133.9	31.98
3400-20MPT-340	170	3400	133.9	37.50
3800-20MPT-115	190	3800	149.6	14.17
3800-20MPT-170	190	3800	149.6	20.95
3800-20MPT-230	190	3800	149.6	28.35
3800-20MPT-290	190	3800	149.6	35.75
3800-20MPT-340	190	3800	149.6	41.91
4200-20MPT-115	210	4200	165.4	15.67
4200-20MPT-170	210	4200	165.4	23.16
4200-20MPT-230	210	4200	165.4	31.33
4200-20MPT-290	210	4200	165.4	39.51
4200-20MPT-340	210	4200	165.4	46.32
4600-20MPT-115	230	4600	181.1	17.16
4600-20MPT-170	230	4600	181.1	25.37
4600-20MPT-230	230	4600	181.1	34.32
4600-20MPT-290	230	4600	181.1	43.27
4600-20MPT-340	230	4600	181.1	50.73

Panther® Sleeves



- Full factory width sleeves
- Sleeve edges are trimmed before shipment
- Sleeves cannot be accepted for return

Timken maintains inventory of most synchronous sleeve sizes. Contact customer service for availability. Minimum order quantity and/or lead times may apply.

Occasional production inconsistencies which may render a portion of the sleeve unusable can be present as a normal part of the production process.

Each sleeve is inspected to ensure that it contains 90% or more usable product. A full width sleeve with less than 10% unusable product is considered acceptable.

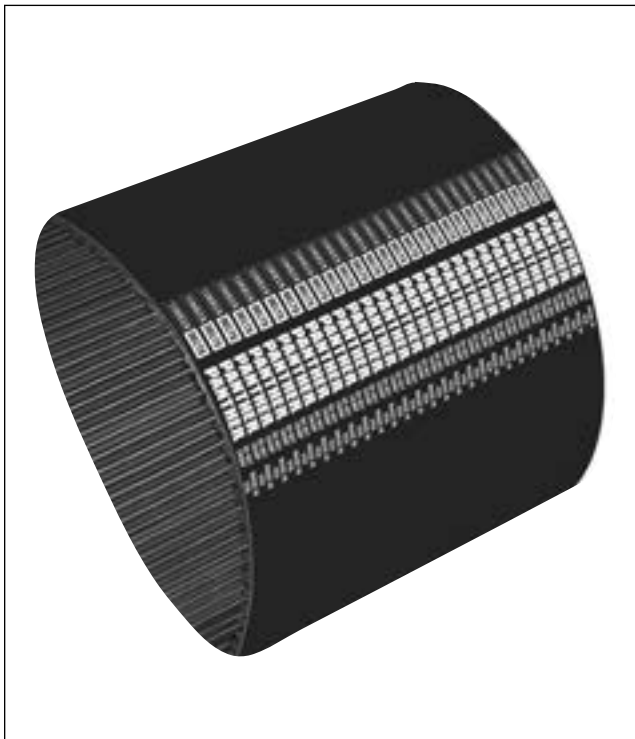

Panther® Sleeve Part Numbers

Part Number	Sleeve Width (mm)	Sleeve Weight (lbs)
8M Pitch – High Torque Synchronous (HTS) Sprockets: MPB, QD, Taper Bushed (8mm)		
480-8MPT-470SL	470	2.7
560-8MPT-470SL	470	3.2
600-8MPT-470SL	470	3.4
640-8MPT-470SL	470	3.6
720-8MPT-470SL	470	4.1
800-8MPT-470SL	470	4.5
880-8MPT-470SL	470	5.0
896-8MPT-470SL	470	5.1
920-8MPT-470SL	470	5.2
960-8MPT-470SL	470	5.4
1000-8MPT-470SL	470	5.7
1040-8MPT-470SL	470	5.9
1120-8MPT-470SL	470	6.4
1152-8MPT-470SL	470	6.5
1200-8MPT-470SL	470	6.8
1224-8MPT-470SL	470	6.9
1248-8MPT-470SL	470	7.1
1280-8MPT-470SL	470	7.3
1360-8MPT-470SL	470	7.7
1400-8MPT-470SL	470	7.9
1440-8MPT-470SL	470	8.2
1600-8MPT-470SL	470	9.1
1760-8MPT-470SL	470	10.0
1800-8MPT-470SL	470	10.2
1904-8MPT-470SL	470	10.8
2000-8MPT-470SL	470	11.3
2104-8MPT-470SL	470	11.9
2200-8MPT-470SL	470	12.5
2240-8MPT-470SL	470	12.7
2400-8MPT-470SL	470	13.6
2600-8MPT-470SL	470	14.7
2800-8MPT-470SL	470	15.9
3048-8MPT-470SL	470	17.3

Part Number Example: **1400-8MPT-470SL** = **1400** - **8M** **PT** - **470** **SL**
Pitch Length (millimeters) Tooth Pitch Panther Construction (RPP tooth profile) Width (millimeters) Sleeve

Part Number	Sleeve Width (mm)	Sleeve Weight (lbs)
8M Pitch – High Torque Synchronous (HTS) Sprockets: MPB, QD, Taper Bushed (8mm)		
3280-8MPT-470SL	470	18.6
3600-8MPT-470SL	470	20.4
4400-8MPT-470SL	470	24.9
14M Pitch – High Torque Synchronous (HTS) Sprockets: MPB, QD, Taper Bushed (14mm)		
966-14MPT-470SL	470	9.1
1092-14MPT-470SL	470	10.3
1190-14MPT-470SL	470	11.2
1400-14MPT-470SL	470	13.2
1610-14MPT-470SL	470	15.2
1750-14MPT-470SL	470	16.5
1764-14MPT-470SL	470	16.6
1778-14MPT-470SL	470	16.7
1792-14MPT-470SL	470	16.9
1820-14MPT-470SL	470	17.1
1848-14MPT-470SL	470	17.4
1862-14MPT-470SL	470	17.5
1890-14MPT-470SL	470	17.8
1904-14MPT-470SL	470	17.9
1960-14MPT-470SL	470	18.5
2100-14MPT-470SL	470	19.8
2310-14MPT-470SL	470	21.8
2450-14MPT-470SL	470	23.1
2590-14MPT-470SL	470	24.4
2800-14MPT-470SL	470	26.4
3150-14MPT-470SL	470	29.7
3360-14MPT-470SL	470	31.6
3500-14MPT-470SL	470	33.0
3850-14MPT-470SL	470	36.3
4326-14MPT-470SL	470	40.7
4578-14MPT-470SL	470	43.1
4956-14MPT-540SL	540	46.7

Part Number	Sleeve Width (mm)	Sleeve Weight (lbs)
20M Pitch – High Torque Synchronous (HTS) Sprockets: MPB, QD, Taper Bushed (20mm)		
2000-20MPT-570SL	570	30.5
2500-20MPT-570SL	570	38.1
3400-20MPT-570SL	570	51.8
3800-20MPT-570SL	570	57.9
4200-20MPT-570SL	570	64.0
4600-20MPT-570SL	570	70.1